

Quantum Pixel+

Installation Instructions

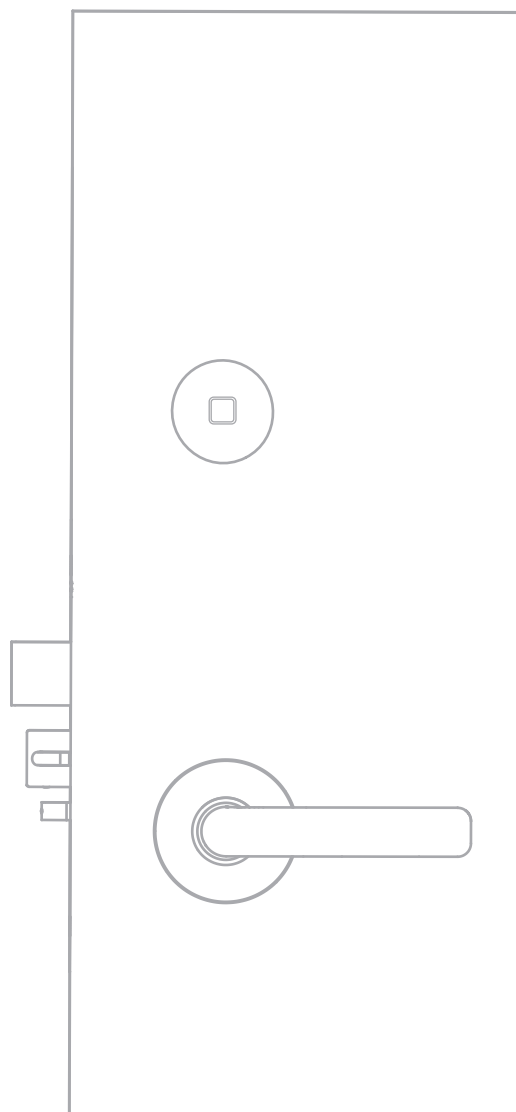

Table of contents

1	Technical specifications	3
1.1	Important information	3
1.2	Parts list	3
2	Lock trim installation	4
2.1	Tools required	4
2.2	Installing lower mortise	4
2.3	Installing controller assembly	5
2.4	Installing reader assembly	7
2.5	Powering up lock	8
2.6	Installing thumb turn	8
2.7	Installing lever set	9
2.8	Installing faceplates	9
2.9	Installing strike	9
3	Lock functionality	10
3.1	Initial lock testing (Construction mode)	10
3.2	Programming lock	10
3.3	Final lock testing	10
4	Maintenance	11
4.1	Removing reader cover	11
4.2	Emergency power override	11
4.3	Replacing battery pack	11
5	Pixel+ lock upgrade kit installation	12
5.1	Removing existing Pixel controller	12
5.2	Installing communication module	12
5.3	Mounting bracket and installing controller	13
6	Door unit inspection criteria	13
6.1	Appearance	13
6.2	Lock function	13
6.3	Electronics/keycards	13
6.4	Door function	13
7	Certifications	14
7.1	FCC and ISED warnings	14
7.2	CE Mark / EN14846	14

1 Technical specifications

1.1 Important information

- All parts needed to install the Quantum Pixel+ lock are included with each unit. Please check to make sure all parts are accounted for before you begin the installation. Do not substitute any of the parts. The use of substitute parts will result in poor performance of the lock.
- All information contained herein, including but not limited to product pricing and other intellectual property, is confidential and intended for the sole use of the addressee(s) so named. Any misuse of this confidential information contained herein may result in legal action by dormakaba USA Inc. and its parent company.

NOTE: See section 8 for EN 14846 certification details.

NOTE: For higher precision, it is recommended that doors are prepped at factory. Door preparation templates are available upon request.

IMPORTANT: Do not drill both STD and ADB Ø7/16 thumb turn holes. Drill only hole that corresponds to mortise purchased. Do not drill a Ø7/16 thumb turn hole for utility locks.

1.2 Parts list

Fig. 1

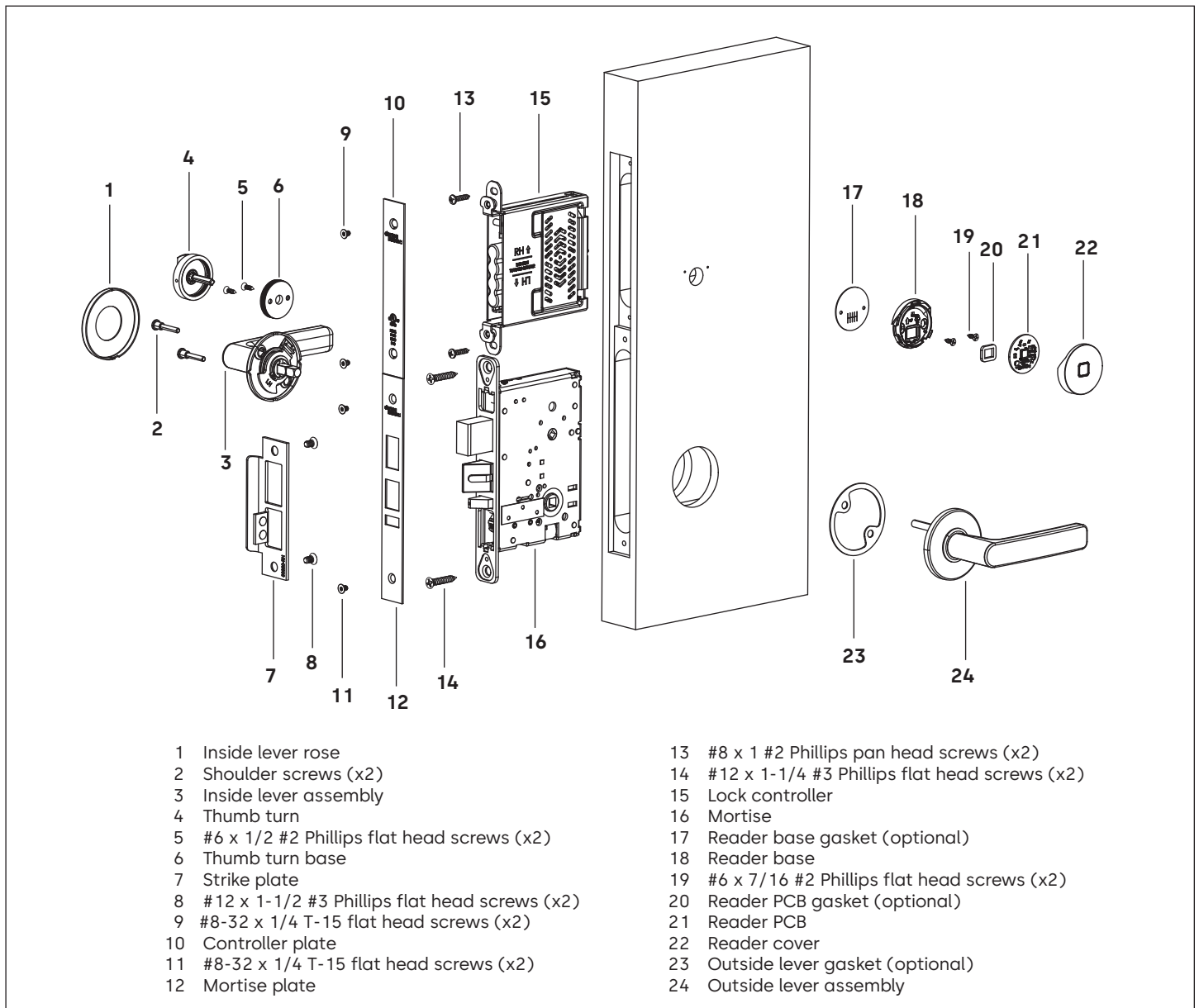

2 Lock trim installation

2.1 Tools required

Table 1

Driver handle (P/N: 24190)	Drill	T-15 tamper resistant torx bit (P/N: A39250)
#1 Phillips bit	1/16" drill bit	Spanner wrench for thumb turn (P/N: A32370)
#2 Phillips bit	1/8" drill bit	
#3 Phillips bit	11/64" drill bit	

2.2 Installing lower mortise

Fig. 2

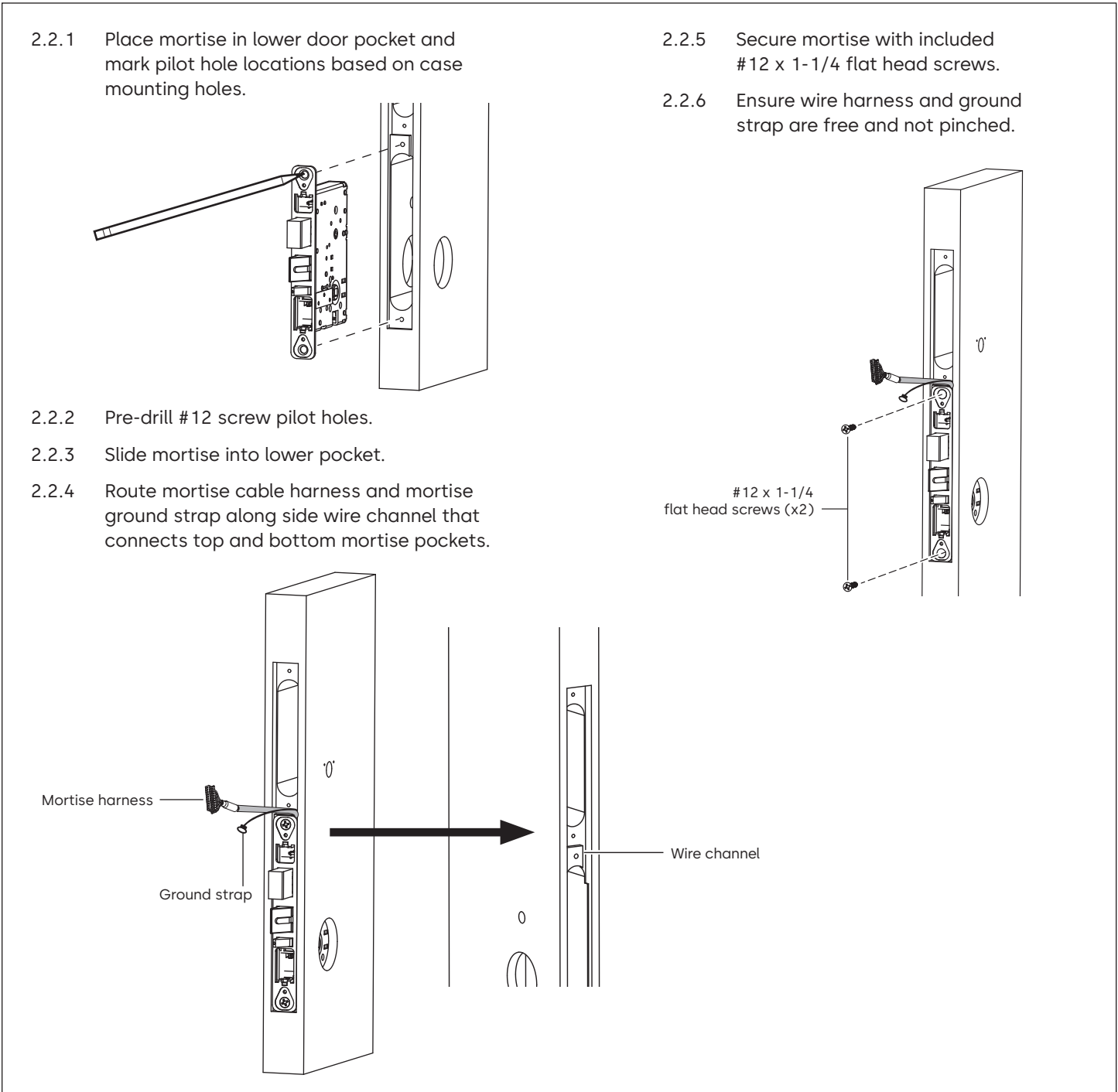

2.3 Installing controller assembly

Fig. 3

NOTE: Refer to section 5 for Pixel+ upgrade kit instructions.

2.3.1 Align controller with upper door pocket in proper orientation with handing mark facing outside face of door and desired handing pointing up.

NOTE: Controller is NOT handed. Controller harness wire will always exit case in same location. When rotated for left handed door, wire will be exiting top of case.

2.3.2 Route reader wire through two tabs on back side of chassis, starting with middle tab and ending with bottom tab, by rolling wire under tabs.

2.3.3 Bend bottom tab slightly over wire to hold it in place, ensuring not to damage wire.

NOTE: Reader wire will always route through bottom tab regardless of handing. Only controller orientation will change.

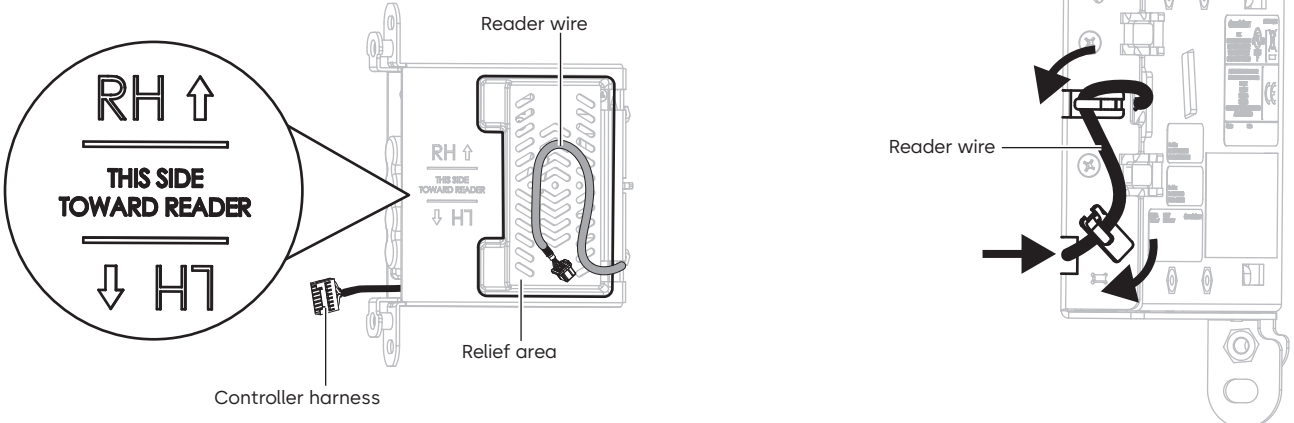

Diagram labels: RH ↑, THIS SIDE TOWARD READER, ↓ H7, Controller harness, Reader wire, Relief area, Reader wire.

Fig. 4

2.3.4 Feed reader wire through hole in front of door and pull while inserting controller in upper door pocket.

NOTE: Ensure reader wire is captured in wire relief area as shown in Fig. 3.

2.3.5 Lift controller to center vertically and horizontally in pocket and mark pilot hole locations based on case mounting holes.

2.3.6 Pre-drill #8 screw pilot holes, ensuring holes are centered for proper face plate alignment.

2.3.7 Slide tray out partially from controller to ensure tabs are not bent while securing #8 screws.

2.3.8 Lift and center assembly to ensure proper alignment.

2.3.9 Secure upper mounting hole with included #8 pan head screw.

NOTE: This side towards reader side of door.

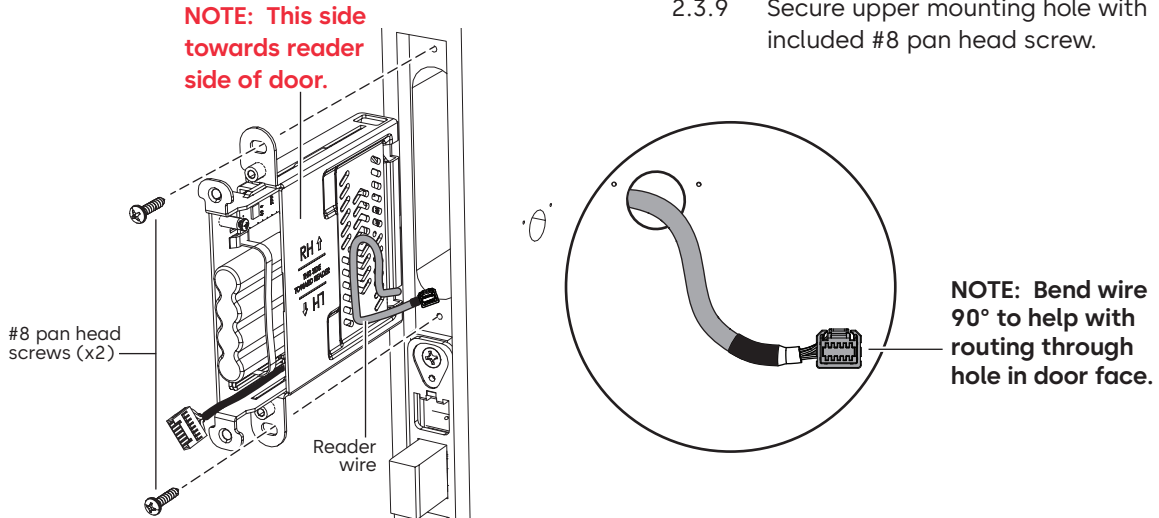
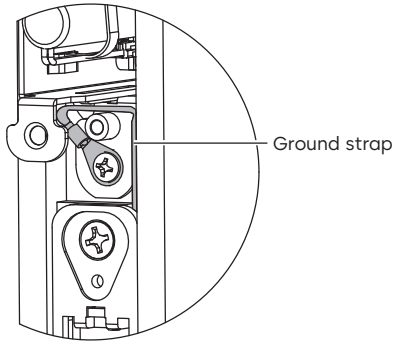

Diagram labels: #8 pan head screws (x2), Reader wire, NOTE: Bend wire 90° to help with routing through hole in door face.

Fig. 5

- 2.3.10 Route ground strap on lower controller mounting hole as shown below and secure with included #8 pan head screw.



NOTE: If ground strap is not present, lock should be upgraded to include ground strap (P/N: A38200) following Pixel grounding update process. Please reach out to dormakaba representative.

- 2.3.11 Slide tray out partially to ensure all connections are secure.

NOTE: Do not connect battery at this point.

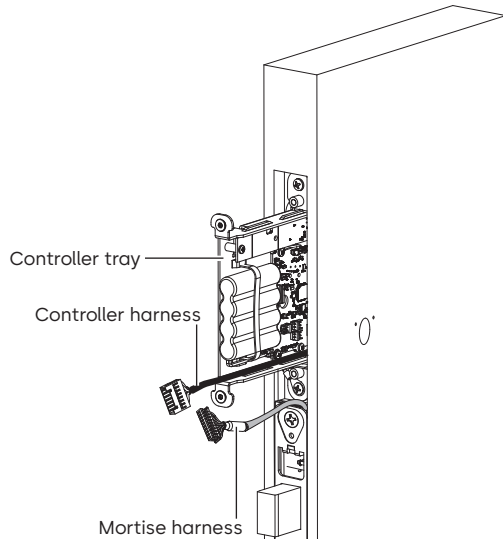

- 2.3.12 Connect harnesses from mortise and controller together as shown below.

NOTE: Do not seat slide tray in door at this point.

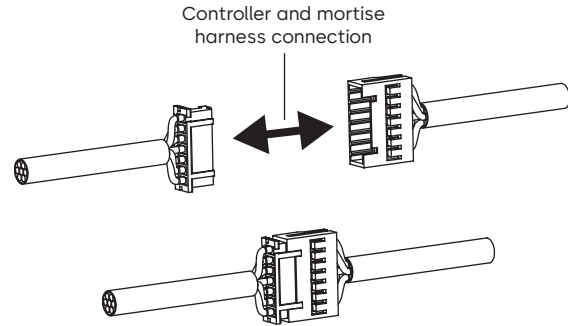

2.4 Installing reader assembly

Fig. 6

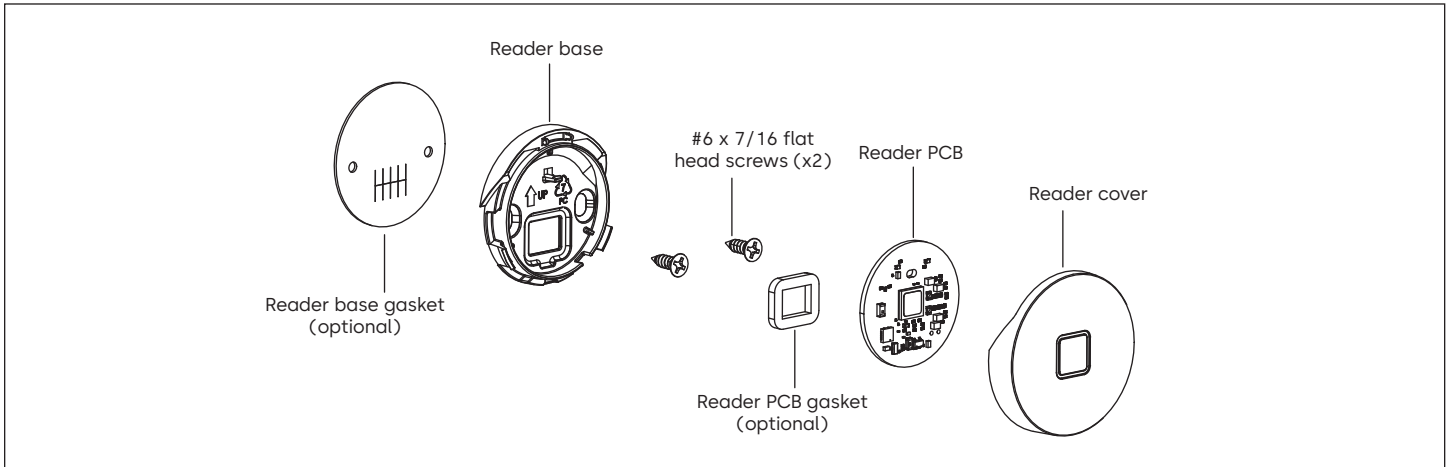

Fig. 7

- 2.4.1 Thread reader wire through square hole in reader base. If exterior door, install reader base gasket between reader base and door.
- 2.4.2 Align reader base with pilot holes on door.
- 2.4.3 Secure reader base to outside of door using included #6 flat head screws.

NOTE: Do not overtighten. Ensure base is fully seated against door.

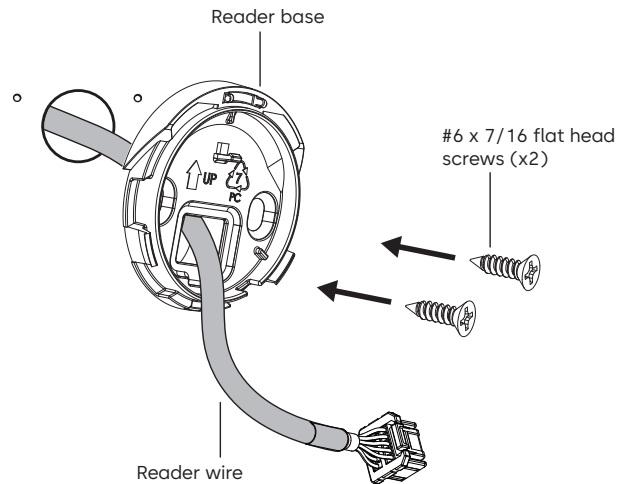
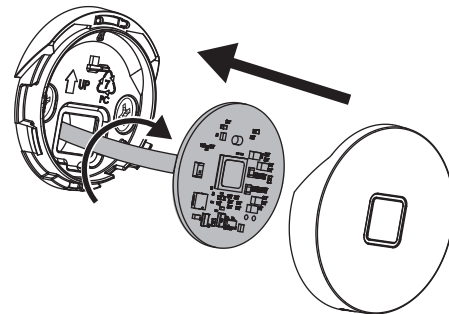
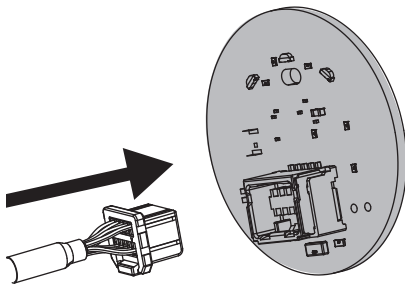

Fig. 8

- 2.4.4 Plug reader wire into reader PCB. If exterior door, ensure reader PCB gasket is installed over reader wire connector before plugging into reader PCB.



NOTE: Push reader wire back into door by twisting while feeding excess wire into door.

- 2.4.5 Push reader PCB secure with clip onto base.
- 2.4.6 Attach reader cover by aligning tabs and pushing. Cover will snap on.

NOTE: Arrows shown on reader base and cover should be pointing up.

2.5 Powering up lock

Fig. 9

- 2.5.1 Connect battery to reader PCB as shown below. Green LEDs should flash 4 times.

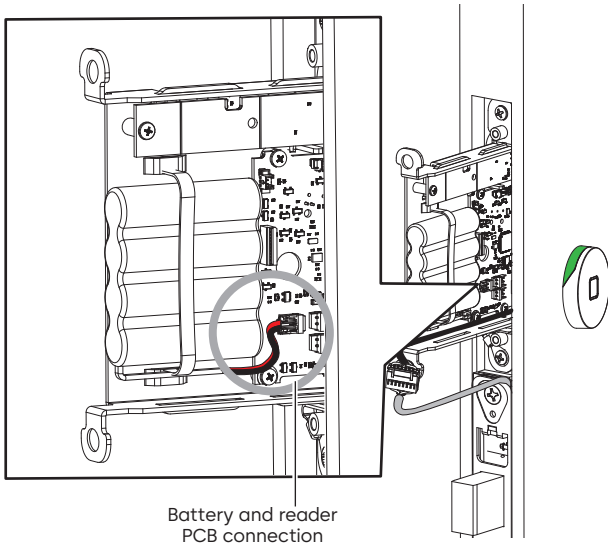

- 2.5.2 Present valid keycard to reader. Red and green LEDs will flash and motor will activate.
- 2.5.3 Seat tray into controller being careful to not pinch any wires.

NOTE: Arrange mortise and controller harness connections as shown below.

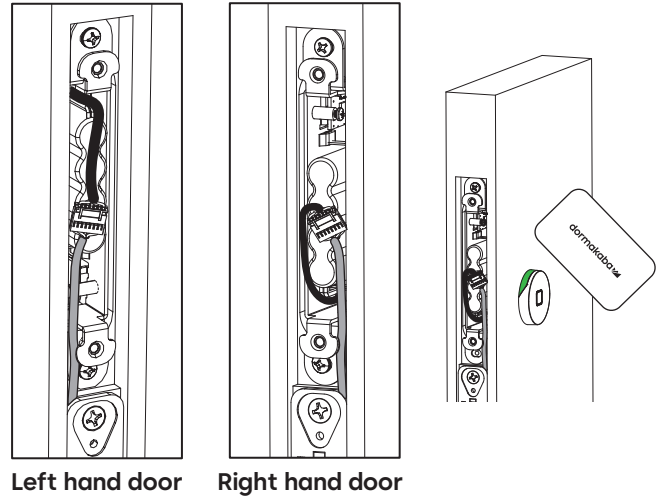

2.6 Installing thumb turn

Fig. 10

- 2.6.1 Center thumb turn base over mortise cam, not hole in door.
- 2.6.2 Mark hole centers using center punch to ensure alignment is maintained.
- 2.6.3 Drill small pilot hole with a short depth to aid in securing screws.

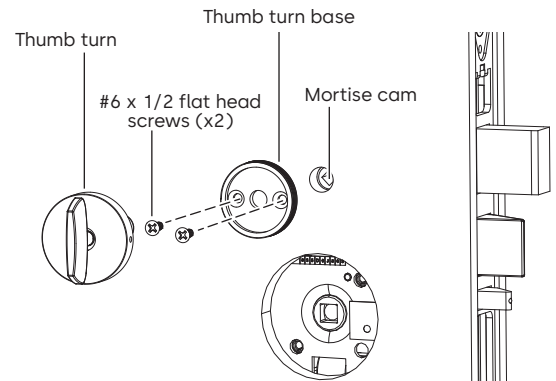
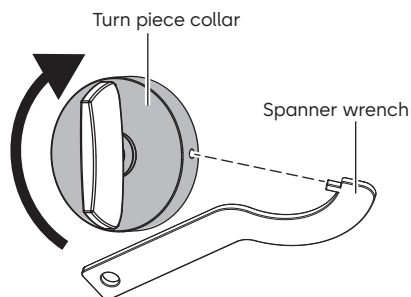
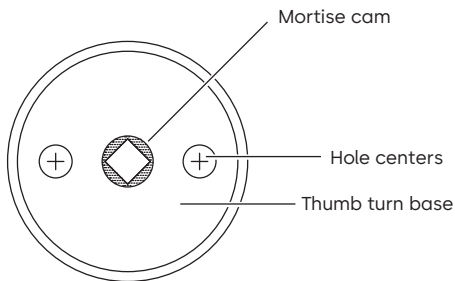

- 2.6.4 Secure base to door with #6 x 1/2 flat head screws.
- 2.6.5 Align turn piece onto base so that it is at 12 and 6 o'clock.
- 2.6.6 Install turn piece onto base by screwing collar on clockwise until tight; torque secure with spanner wrench.
- 2.6.7 Check the turn for smooth operation ensuring no drag or binding occurs.

NOTE: If binding occurs, verify base alignment with mortise cam.

2.7 Installing lever set

Fig. 11

- 2.7.1 Place outside lever rose assembly on outside of door.

NOTE: If exterior door, install gasket over lever assembly posts before lever rose installation.

- 2.7.2 Place inside lever rose assembly on inside of door.

- 2.7.3 Secure to outside rose assembly using included shoulder screws.

- 2.7.4 Carefully slide inside lever rose over lever and ensure removal notch is aligned below lever set for concealment, then fully seat rose over lever assembly.

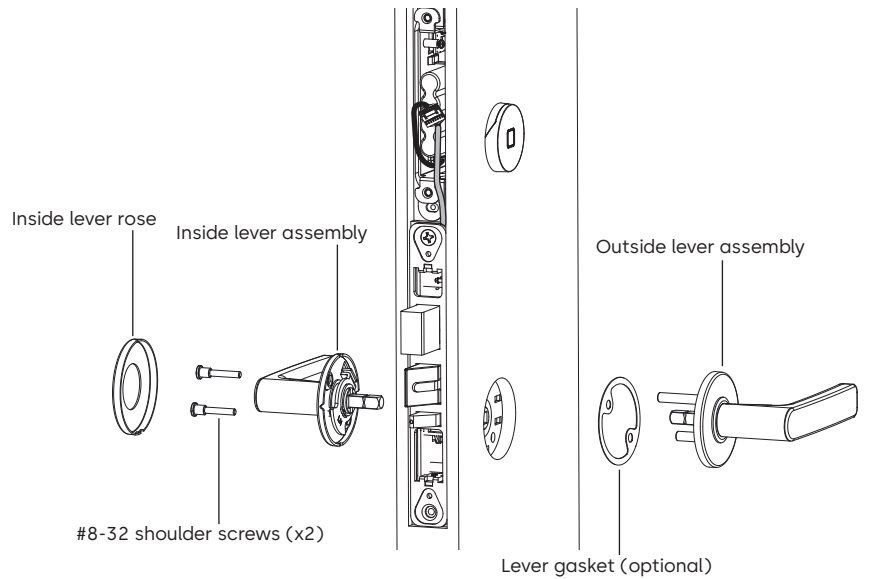

2.8 Installing faceplates

Fig. 12

- 2.8.1 Install lower mortise faceplate with #8 flat head screws.

- 2.8.2 Install upper controller assembly faceplate with #8 flat head screws.

NOTE: Ensure controller harness does not become pinched when securing faceplates.

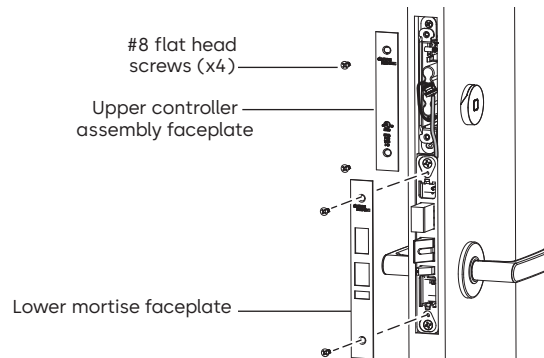

2.9 Installing strike

Fig. 13

- 2.9.1 Align strike plate with mounting holes in door frame.

- 2.9.2 Secure with #12 flat head screws.

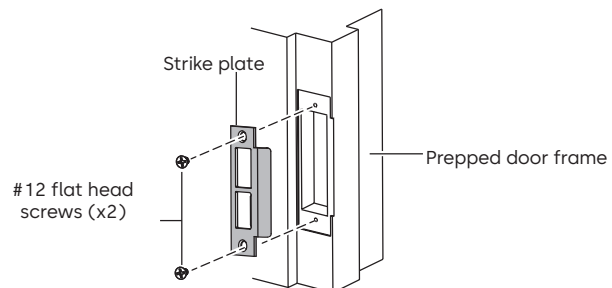

3 Lock functionality

3.1 Initial lock testing (Construction mode)

- 3.1.1 Present a valid opening key to the reader.
- 3.1.2 Ensure lock unlatches, lever turns freely, and lock re-latches.

3.2 Programming lock

- 3.2.1 Use HH6 to program lock to desired room number.
- 3.2.2 Refer to *Maintenance Unit Programming Guide (PK3725)*.
- 3.2.3 If online communication, bind to hub per online communication binding process.
- 3.2.4 If using Hilton BLE, bind per Hilton BLE binding process.

3.3 Final lock testing

- 3.3.1 Present a valid opening key to reader.
- 3.3.2 Ensure reader flashes the green LED 8 times.
- 3.3.3 Ensure lock unlatches, lever turns freely, and lock re-latches.
- 3.3.4 With door open; throw deadbolt and activate privacy.
- 3.3.5 Present valid opening key to reader.
- 3.3.6 Ensure reader flashes the yellow LED 12 times.
- 3.3.7 Rotate inside lever to retract deadbolt and thumb turn.
- 3.3.8 Ensure I/S lever retracts smoothly.

Table 2

Standard LED indicators / Troubleshooting	
LED patterns / Problem observed	Function description / Potential cause
Red and green LEDs flash 9 times simultaneously	Time and date not set, use the HH6 to set
Yellow LED flashes 12 times	Deadbolt is thrown , mortise cable is not connected to controller, deadbolt connector is not connected on MT6 main PCB, or cables are damaged
Yellow LED flashes 2 times	Keycard not allowed OR keycard cancelled by new keycard
Red and green LEDs flash alternately 9 times	Low battery (contact dormakaba customer service)
Yellow and red LEDs flash 2 times simultaneously	Bad keycard read or corrupted data (may require new keycard)
Reader wire is hard to install into door during installation	Controller case may be installed in incorrect orientation with wire relief area facing inside of door instead of outside

4 Maintenance

4.1 Removing reader cover

Fig. 14

- 4.1.1 Insert approx. 1/8" [3mm] x 5-1/2" [140 mm] long slotted screwdriver into slot on underside of reader.
- 4.1.2 Push screwdriver up until it can be felt seating between base and cover.
- 4.1.3 Slowly turn screwdriver until cover releases, creating a clicking noise.

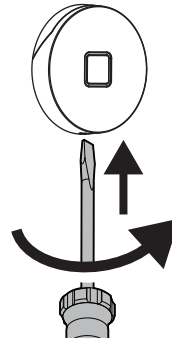

NOTE: Alternatively, insert screwdriver into slot and pull straight outwards to pull reader cover off door.

4.2 Emergency power override

Fig. 15

- 4.2.1 Insert adapter cable into USB slot on backup device.
- 4.2.2 Remove reader cover as shown in step 4.1.
- 4.2.3 Insert power override cable pins into holes in reader.
- 4.2.4 Press and hold orange button on backup device to apply power to lock.
- 4.2.5 Allow time for lock to power up as normal.
- 4.2.6 Use opening key on door to gain access.
- 4.2.7 Release backup device button and disconnect from reader once access is gained.

Battery backup device
(P/N: 118-515990)

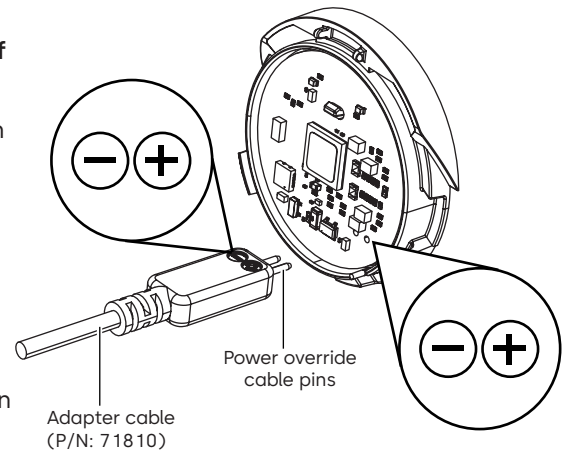
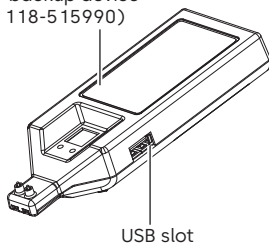

4.3 Replacing battery pack

Fig. 16

- 4.3.1 Remove two upper controller faceplate screws.
- 4.3.2 Slide tray out to expose battery and connection and unplug battery from controller.
- 4.3.3 Remove battery spring clip.
- 4.3.4 Replace battery pack and reattach spring clip.
- 4.3.5 Plug in battery and ensure harness connection wires are repositioned in case as in step 2.5.
- 4.3.6 Slide tray back into door and reattach faceplate with screws.
- 4.3.7 Use HH6 to set time and date if not connected to online system that will automatically update it on power up.

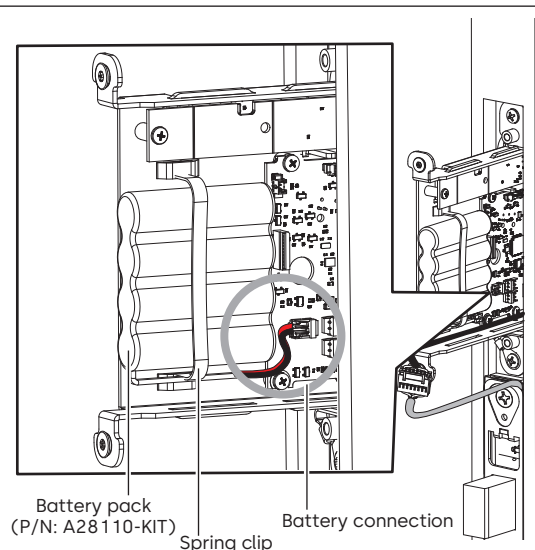

5 Pixel+ lock upgrade kit installation

5.1 Removing existing Pixel controller

Fig. 17

5.1.1 Remove reader by removing reader cover ([see Quantum Pixel Installation Guide](#)), PCB mounting screw, and reader base mounting screws.

5.1.2 Remove upper and lower faceplates from door by removing four screws.

Note: Do not discard screws.

5.1.3 Remove Pixel controller by removing two mounting screws.

Note: Do not discard screws.

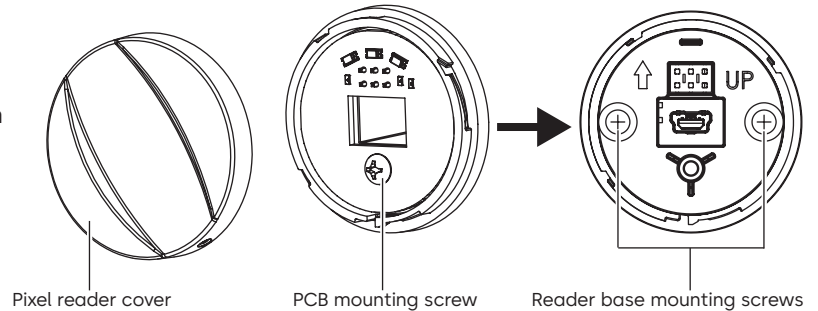

5.2 Installing communication module (if using existing Pixel lock module)

Fig. 18

5.2.1 Remove communication module from existing Pixel lock controller by removing mounting screw and disconnecting wire harness.

5.2.2 Discard mounting screw used in existing Pixel lock.

5.2.3 Remove mounting screw from new Pixel+ controller.

5.2.4 Insert communication module in orientation based on module type.

ENSURE:

- Back side of communication module installed between circuit board retention tabs.
- Wire connector is in correct location.
- Wires are routed properly.

5.2.5 Secure with mounting screw from new Pixel+ controller.

5.2.6 Connect wire to main circuit board, press wires down over connector, and ensure proper wire routing.

5.2.7 Continue from section 5.3.

Zigbee communication module

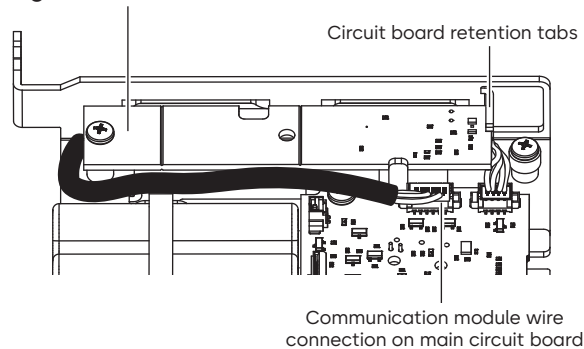

Inncom communication module

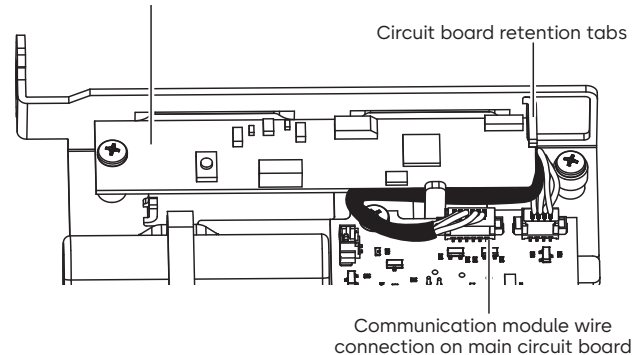

5.3 Mounting bracket and installing controller

Fig. 19

- 5.3.1 Affix bracket to controller using included screw in upgrade kit box.

NOTE: Tab on bracket should insert into hole on back of chassis.

NOTE: Ensure bracket and controller are oriented as shown below.

- 5.3.2 Continue installation from section 2.3, skipping sections 2.6, 2.7, and 2.9.

NOTE: The original #12 controller mounting screws, #8 faceplate screws, and controller faceplate from Pixel lock will be reused. Do not discard.

Front view

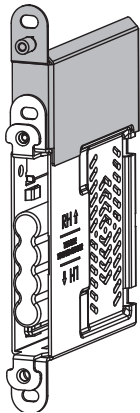

Back view

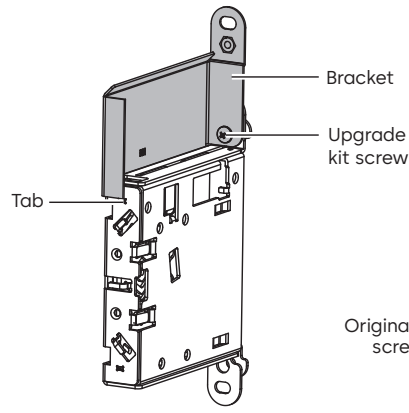

Upgrade bracket kit P/N:
Right hand: A32490-LH-KIT
Left hand: A32490-RH-KIT

(Includes handed bracket assembly and mounting screw)

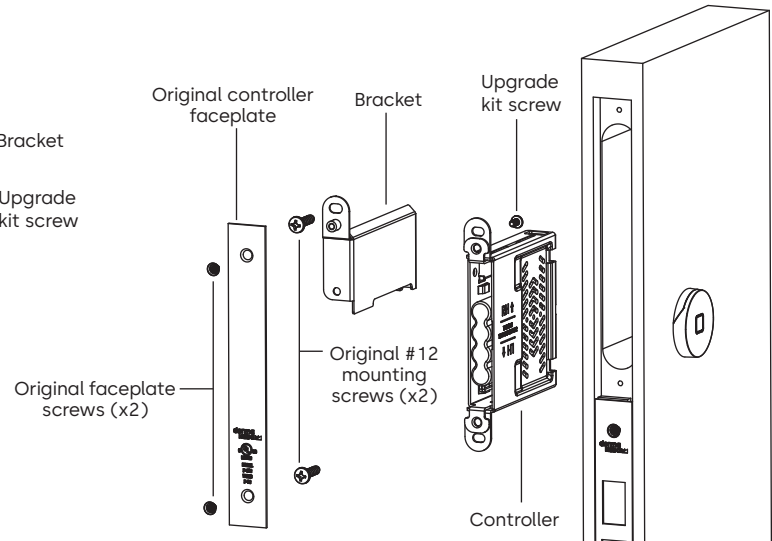

6 Door unit inspection criteria

6.1 Appearance

- Finish is free of blemishes or scratches that would distract from lock appearance.
- Lock body and under plate (if used) are mounted straight on the door.
- Door scalp is mounted straight and flush with the door edge.
- Jamb strike is mounted straight and is flush with the jamb face.
- Correction of minor blemishes on the door jamb are the responsibility of the property's maintenance department.

6.2 Lock function

- Knob or lever rotates and moves freely.
- Lever is horizontal to floor when at rest position.
- Deadbolt extends fully and retracts without binding when door is open.
- Lock latch and dead bolt engage jamb strike plate freely.
- Anti-pick latch when depressed when door is open.
- Anti-pick latch is depressed when contact is made with the strike plate when door is closed.

6.3 Electronics/keycards

- Present keycard in front of reader, and the yellow light flashes twice when incorrect keycard is used.
- Green light flashes when the proper keycard is used.
- Green light is flashing when the lever is operated.
- Green light continues to flash for a five-second cycle.
- Yellow light flashes 12 times when the dead bolt is extended and a guest/hotel keycard is used.
- All keycards function to the specifications of the properties key design.

6.4 Door function

- Door closes and latches with little or no interference.
- Deadbolt extends fully through the strike plate without interference when door is closed.
- Spacing between door edge and inside door jamb does not exceed 3/16" when door is closed.

NOTE: If bumpers or other seals are added after strike plate installation and causes alignment and latch problems, it is the property's responsibility to correct this condition. This note generally applies to new construction or new door installation.

7 Certifications

7.1 FCC and ISED warnings

ISED non-interference disclaimer

This device complies with Industry Canada license-exempt RSS standard(s). Operation is subject to the following two conditions: (1) this device may not cause interference, and (2) this device must accept any interference, including interference that may cause undesired operation of the device. This equipment complies with ISED RSS-102 radiation exposure limits set forth for an uncontrolled environment. This transmitter must be installed to provide a separation distance of at least 20 cm from all persons and must not be co-located or operating in conjunction with any other antenna or transmitter.

Le présent appareil est conforme aux CNR d'Industrie Canada applicables aux appareils radio exempts de licence. L'exploitation est autorisée aux deux conditions suivantes : (1) l'appareil ne doit pas produire de brouillage, et (2) l'utilisateur de l'appareil doit accepter tout brouillage radioélectrique subi, même si le brouillage est susceptible d'en compromettre le fonctionnement."Cet équipement est conforme avec ISED RSS-102 des limites d'exposition aux rayonnements définies pour un environnement non contrôlé. Cet émetteur doit être installé à au moins 20 cm de toute personne et ne doit pas être colocalisé ou fonctionner en association avec une autre antenne ou émetteur.

FCC compliance statement

This equipment has been tested and found to comply with the limits for a Class B digital device, pursuant to part 15 of the FCC Rules. These limits are designed to provide reasonable protection against harmful interference in a residential installation. This equipment generates, uses, and can radiate radio frequency energy and, if not installed and used in accordance with the instructions, may cause harmful interference to radio communications. However, there is no guarantee that interference will not occur in a particular installation. If this equipment does cause harmful interference to radio or television reception, which can be determined by turning the equipment off and on, the user is encouraged to try to correct the interference by one or more of the following measures:

- Reorient or relocate the receiving antenna.
- Increase the separation between the equipment and receiver.
- Connect the equipment into an outlet on a circuit different from that to which the receiver is connected.
- Consult the dealer or an experienced radio/TV technician for help.

Changes or modifications not expressly approved by the party responsible for compliance could void the user's authority to operate the equipment. This device complies with part 15 of the FCC Rules. Operation is subject to the following two conditions: (1) This device may not cause harmful interference, and (2) this device must accept any interference received, including interference that may cause undesired operation.

RF exposure statement

This equipment complies with FCC radiation exposure limits set forth for an uncontrolled environment. This transmitter must not be co-located or operating in conjunction with any other antenna or transmitter. To avoid the possibility of exceeding the FCC radio frequency exposure limits, this equipment should be installed and operated with minimum distance 20 cm between the antenna and your body during normal operation. Users must follow the specific operating instructions for satisfying RF exposure compliance.

7.2 CE Mark / EN14846

		dormakaba Canada Inc. 105 blvd Marcel-Laurin Montréal, QC Canada H4N 2M3	
DOP_0175 0432-CPR-00072-03.01		23	
EN 14846:2008	3	S	5 D 0 J 3 0 3

		WAH MEI Access Security Technology Co., Ltd. No.28, Haigang Road, Guanghai Town, Taishan City, Guangdong Province, China	
DOP_0175 0432-CPR-00072-03.01		23	
EN 14846:2008	3	S	5 D 0 J 3 0 3

T95524_A EN, 08/2024
Subject to change without notice



dormakaba.com

Online consumable orders
dormakabalodgingstore.com

Technical support
lodgingsupport@dormakaba.com
www.dormakabalodgingsupport.com

dormakaba USA inc.
6161 E 75th Street
Indianapolis, IN 46250

T: 1 800 999 6213
dormakaba.us